



# DOUBLE FOOT PEDAL VALVE

## Z85500-WM TAG \_\_\_\_\_



### Engineering Specifications: Zurn AquaSpec® Z85500-WM

Polished chrome-plated brass wall-mounted, self-closing double pedal mixing valve. Two 1/2" NPT angle stop inlets on 2-1/2" [64mm] centers and one 3/8" NPT top female outlet.

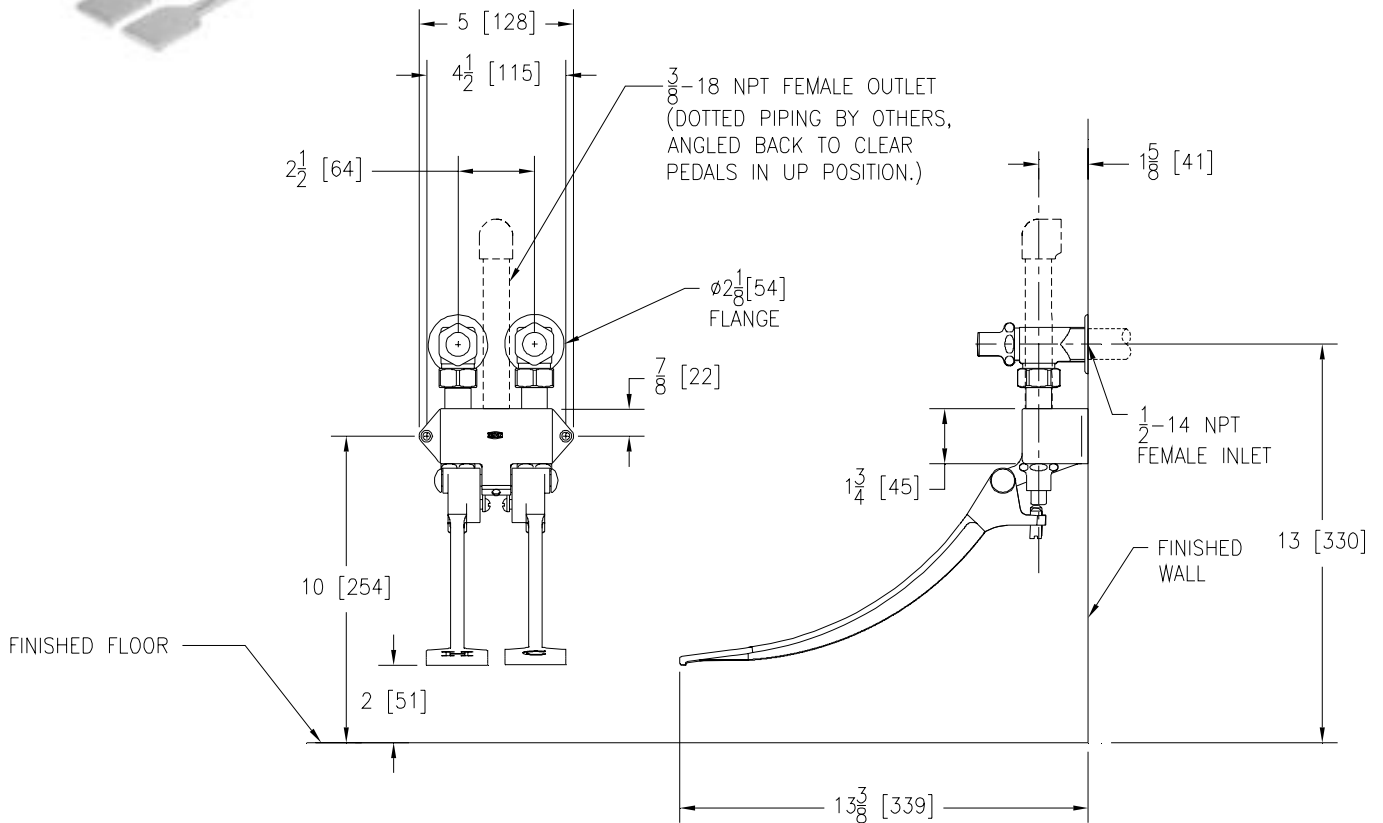

Note: All dimensions are for reference only. Do not use for pre-plumbing



[www.GreenSpec.com](http://www.GreenSpec.com)

### OPTIONAL ACCESSORIES

Suffix	Description
___-VC	Volume Control

ZURN INDUSTRIES, LLC ♦ COMMERCIAL BRASS OPERATION ♦ 2640 SOUTH WORK STREET ♦ FALCONER NY 14733

Phone: 1-716-665-1132 ♦ Fax: 1-716-665-1135 ♦ World Wide Web: [www.zurn.com](http://www.zurn.com)

In Canada: ZURN INDUSTRIES LIMITED ♦ 3544 Nashua Drive ♦ Mississauga, Ontario L4V1L2 ♦ Phone: 905/405-8272 Fax: 905/405-1292