

# AQUASPEC<sup>®</sup> FAUCETS

MODEL - Z83100-XL WIDESPREAD SERIES



## TECHNICAL INFORMATION

---

**FLOW:** 2.2 GPM [8.3 L] PRESSURE COMPENSATING AERATOR \*

**MAXIMUM PRESSURE:** 125 PSI

**MAXIMUM TEMPERATURE:** 180 F

**HANDLE NUT TORQUE:** 15-20 FT - LBS.

**CARTRIDGE STYLE:** QUARTER TURN CERAMIC DISK

\* OTHER AERATORS AVAILABLE BY REQUEST

---

## INSTALLATION INSTRUCTIONS

### Z83100 (SEE FIGURE 1)

1. PLACE GASKET (ITEM #3D) ONTO SHANK OF BASE (ITEM #4). PLACE BASE THROUGH CENTER HOLE OF SINK AND SECURE TO SINK USING WASHER (ITEM #3E), LOCKWASHER (ITEM #3F) AND FLANGED MOUNTING NUT (ITEM #3G).
2. REMOVE BODY (ITEMS #7, #8, & #9) FROM PACKAGING AND PLACE WASHER (ITEM #3C) ONTO END FITTINGS, SCREW NUTS ALL THE WAY DOWN ON THREADS.
3. PLACE BODY (ITEM #9) INTO SINK FROM UNDERSIDE AND PLACE WASHER (ITEM #3B) AND RETAINING RING (ITEM #3A) ONTO SHANKS ABOVE SINK TOP.
4. HAND TIGHTEN NUTS (ITEM #9A) TO SECURE ASSEMBLY TO SINK. **DO NOT OVERTIGHTEN.**
5. PLACE GASKET (ITEM #7A) BETWEEN TEE (ITEM #7D) & SHANK. SECURE TEE TO SHANK WITH NUT (ITEM #7C).
6. TIGHTEN ESCUTCHEONS (ITEM #1) ONTO CARTRIDGE CAP (ITEM #2) TO SECURE BODY TO SINK.
7. INSTALL SPOUT INTO BASE AND TIGHTEN NUT (SEE VIEWS FOR SWING/RIGID CONNECTION). SCREW HANDLES ONTO CARTRIDGE STEMS (ITEMS #5 AND #6) AND INSERT INDEX BUTTONS.
8. PROCEED TO "FINISHING INSTALLATION" ALL MODELS SECTION

### Z83100-ICT (SEE FIGURE 2)

1. PLACE GASKET (ITEM #3D) ONTO SHANK OF BASE (ITEM #4). PLACE BASE THROUGH CENTER HOLE OF SINK AND SECURE TO SINK USING WASHER (ITEM #3E), LOCKWASHER (ITEM #3F) AND FLANGED MOUNTING NUT (ITEM #3G).
2. REMOVE BODY (ITEM #8) FROM PACKAGING AND PLACE WASHER (ITEM #3C) ONTO END FITTINGS, SCREW NUTS ALL THE WAY DOWN ON THREADS.
3. PLACE SHANK NUT (ITEM #3J) ONTO CENTER POST OF BODY (ITEM #8). PLACE FRICTION WASHER (ITEM #3i) INTO NUT (ITEM #3J). INSERT SHANK SEAL (ITEM #3H) AROUND CENTER POST WITH LARGE DIAMETER FIRST UNTIL SEAL BOTTOMS OUT.
4. PLACE BODY INTO SINK FROM UNDERSIDE AND PLACE WASHER (ITEM #3B) AND RETAINING RING (ITEM #3A) ONTO SHANKS ABOVE SINK TOP.
5. HAND TIGHTEN NUTS (ITEM #7A) TO SECURE ASSEMBLY TO SINK. **DO NOT OVERTIGHTEN.**
6. TIGHTEN ESCUTCHEONS (ITEM #1) ONTO CARTRIDGE CAP (ITEM #2) TO SECURE BODY TO SINK, ALSO TIGHTEN SHANK NUT (ITEM #3J) ONTO THREADS OF BASE (ITEM #4).
7. INSTALL SPOUT INTO BASE AND TIGHTEN NUT (SEE VIEWS FOR SWING/RIGID CONNECTION). SCREW HANDLES ONTO CARTRIDGE STEMS (ITEMS #5 AND #6) AND INSERT COLOR CODED INDEX BUTTONS.
8. PROCEED TO "FINISHING INSTALLATION" ALL MODELS SECTION

### Z83103 (SEE FIGURE 3)

1. PLACE GASKET (ITEM #3D) ONTO SHANK OF BASE (ITEM #4). PLACE BASE THROUGH CENTER HOLE OF SINK AND SECURE TO SINK USING WASHER (ITEM #3E), LOCKWASHER (ITEM #3F) AND FLANGED MOUNTING NUT (ITEM #3G).
2. REMOVE BODY (ITEMS #7, #8, & #9) FROM PACKAGING, REMOVE CARTRIDGE CAP (ITEM #1) AND PLACE WASHER (ITEM #3C) ONTO END FITTINGS, SCREW NUTS ALL THE WAY DOWN ON THREADS.

ZURN INDUSTRIES, LLC ♦ COMMERCIAL BRASS OPERATION ♦ 2640 SOUTH WORK STREET ♦ FALCONER NY 14733

Phone: 1-800-997-3876 ♦ Fax: 1-919-775-3541 ♦ www.zurn.com

In Canada: ZURN INDUSTRIES LIMITED ♦ 3544 Nashua Drive ♦ Mississauga, Ontario L4V1L2 ♦ Phone: 905/405-8272 Fax: 905/405-1292

PAGE 1 OF 4

Form # CF1197	Date: 11/18/09
C.N. No. 125521	Rev. A

3. PLACE BODY (ITEM #9) INTO SINK FROM UNDERSIDE AND PLACE WASHER (ITEM #3B) AND RETAINING RING (ITEM #3A) ONTO SHANKS ABOVE SINK TOP.
4. REASSEMBLE CARTRIDGE CAP (ITEM #1) TO BODY (ITEM #9).
5. HAND TIGHTEN NUTS (ITEM #9A) TO SECURE ASSEMBLY TO SINK. **DO NOT OVERTIGHTEN.**
6. PLACE GASKET (ITEM #7A) BETWEEN TEE (ITEM #7D) & SHANK. SECURE TEE TO SHANK WITH NUT (ITEM #7C).
7. TIGHTEN ESCUTCHEONS (ITEM #2) BODY (ITEM #9) TO SECURE BODY TO SINK.
8. INSTALL SPOUT INTO BASE AND TIGHTEN NUT (SEE VIEWS FOR SWING/RIGID CONNECTION). SCREW HANDLES ONTO CARTRIDGE STEMS (ITEMS #5 AND #6) AND INSERT INDEX BUTTONS.
9. PROCEED TO "FINISHING INSTALLATION" ALL MODELS SECTION

## **Z83100-HS (SEE FIGURE 4)**

1. FULLY THREAD MOUNTING NUT (ITEM #7C) ONTO DIVERTER TEE (ITEM 6D). PLACE WASHER (ITEM #7B) AND FRICTION GASKET (ITEM #7A) ONTO DIVERTER TEE (ITEM #6D).
2. PLACE DIVERTER TEE (ITEM #6D) INTO SINK FROM UNDERSIDE AND THREAD ESCUTCHEON (ITEM #6A) ON SO THERE'S APPROXIMATELY 1" OF THREADS STICKING OUT ABOVE ESCUTCHEON (ITEM #6A).
3. REMOVE BODY ASSEMBLY (ITEM #9) FROM PACKAGING AND PLACE WASHER (ITEM #3C) ONTO END FITTINGS, SCREW NUTS ALL THE WAY DOWN ON THREADS.
4. PLACE BODY (ITEM #9) INTO SINK FROM UNDERSIDE AND PLACE WASHER (ITEM #3B) AND RETAINING RING (ITEM #3A) ONTO SHANKS ABOVE SINK TOP.
5. HAND TIGHTEN NUTS (ITEM #9A) TO SECURE ASSEMBLY TO SINK. **DO NOT OVERTIGHTEN.**
6. TIGHTEN ESCUTCHEONS (ITEM #1) ONTO CARTRIDGE CAP (ITEM #2) TO SECURE BODY TO SINK.
7. INSTALL SPOUT INTO DIVERTER TEE AND TIGHTEN NUT (SEE VIEWS FOR SWING/RIGID CONNECTION). SCREW HANDLES ONTO CARTRIDGE STEMS (ITEMS #4 AND #5) AND INSERT INDEX BUTTONS.
8. BACK OFF ESCUTCHEON (ITEM #6A) UNTIL SNUG AGAINST SPOUT NUT. TIGHTEN MOUNTING NUT (ITEM #7C) TO SECURE DIVERTER TEE ASSEMBLY (ITEM #6) ON SINK.
9. REMOVE HOSE SPRAY ASSEMBLY (ITEM #11) FROM PACKING. INSERT LOOSE WASHER INTO END OF HOSE. ASSEMBLE HOSE AND SPRAY ESCUTCHEON (ITEM #11A) ONTO SINK. INSERT HOSE AND SPRAY (ITEM #11B) THROUGH ESCUTCHEON (ITEM #11A) FROM TOP OF SINK AND ATTACH TO DIVERTER TEE (ITEM #6D).
10. PROCEED TO "FINISHING INSTALLATION" ALL MODELS SECTION

## **"FINISHING INSTALLATION" ALL MODELS**

1. ATTACH LAVATORY SUPPLIES TO FAUCET USING COUPLING NUT (ITEM #10).
2. OPTIONAL - POP-UP (-P) / GRID STRAINER (-G) / HANDICAP OFFSET GRID DRAIN (-GH) *(NOT AN OPTION FOR Z80000-HS)* INSTALL POP-UP OR GRID STRAINER IN SINK OUTLET AND PLUMB WASTE CONNECTION.
3. INSTALL AERATOR ONTO SPOUT END AND HAND TIGHTEN. IT MAY BE NECESSARY TO UNSCREW AND CLEAN AERATOR AT START-UP.
4. TURN WATER SUPPLY ON AND OPERATE FAUCET CHECKING FOR LEAKS.
5. IT MAY BE NECESSARY TO SHUT WATER OFF AND REMOVE CARTRIDGES TO CLEAN SUPPLY LINES. CARTRIDGES CAN BE REMOVED BY FIRST REMOVING THE HANDLES. COLOR INDEXES CAN BE REMOVED BY INSERTING A PIN INTO THE HOLE ON THE UNDERSIDE OF THE HANDLE. AFTER THE HANDLES HAVE BEEN REMOVED, UNSCREW ESCUTCHEONS (ITEM #1) AND REMOVE THE CARTRIDGE CAPS (ITEM #2). PULL UP ON THE CARTRIDGE.
6. REPLACE CARTRIDGES IN BODY AND HAND TIGHTEN CARTRIDGE CAPS. PLACE HANDLES ON THE CARTRIDGE STEM AND LOCATE THEM AS DESIRED. TIGHTEN CARTRIDGE CAPS.
7. REPLACE HANDLE SCREWS AND COLOR INDEX BUTTONS.

## **MAINTENANCE**

1. YOUR ZURN AQUASPEC FAUCET HAS A HIGHLY POLISHED NICKEL CHROME PLATED FINISH. CLEAN WITH SOAP AND WATER OR A MILD CLEANER WHICH IS SAFE FOR CHROME PLATING. DO NOT USE ACIDS OR TOILET BOWL CLEANER AS THEY WILL DAMAGE THE FINISH.
2. AQUASPEC FAUCETS CONTAIN CERAMIC DISK CARTRIDGES WHICH REQUIRE NO MAINTENANCE. TO REMOVE THE CARTRIDGE, SHUT THE WATER OFF, LOOSEN THE HANDLE NUTS AND PULL UP ON THE CARTRIDGE.

## **REPLACEMENT PARTS**

COLD WATER CARTRIDGE	59517007
HOT WATER CARTRIDGE	59517008
INDEX BUTTONS	G60500

FIGURE 1

Item	Part Number	Description	Qty.
1	60078001	Escutcheon	2
2	60077001	Cartridge Cap	2
3	G61859	Mounting Hardware	1
3A	60383002	Retaining Ring	2
3B	60382001	Washer	2
3C	60444001	Washer	2
3D	60148002	Gasket	2
3E	65340001	Washer	1
3F	61613019	Toothed Lockwasher	1
3G	59530003	Flanged Mounting Nut	1
4	G67871	Base	1
5	59517007	Long Cold Cartridge	1
6	59517008	Long Hot Cartridge	1
7	G67898	Tee Assembly	1
7A	60455001	Gasket	1
7B	63982001	Retaining Ring	1
7C	60145002	Shank Nut	1
7D	61283005	Tee	1
8	93317332	S. S. Flexible Hose	2
9	93039001	Valve Body Assembly	2
9A	60445001	Nut	2
10	59532001	1/2" NPSM Riser Nut	2

Z831A1-XL PICTURED

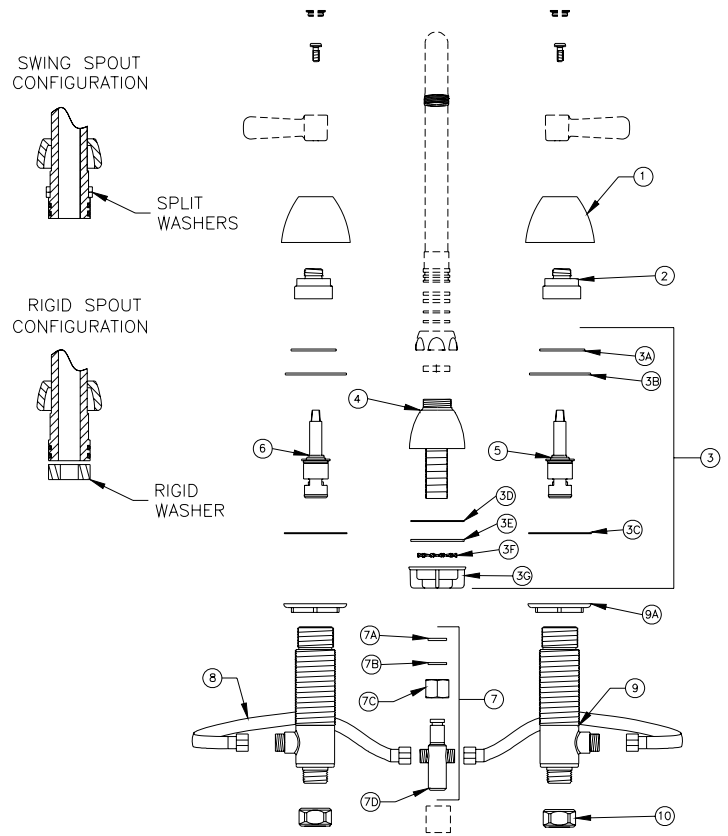

FIGURE 2

Item	Part Number	Description	Qty.
1	60078001	Escutcheon	2
2	60077001	Cartridge Cap	2
3	G61080	Mounting Hardware	1
3A	60383002	Retaining Ring	2
3B	60382001	Washer	2
3C	60444001	Washer	2
3D	60148002	Gasket	1
3E	65340001	Washer	1
3F	61613019	Lockwasher	1
3G	59530003	Flanged Mounting Nut	1
3H	60144001	Shank Seal	1
3I	60399001	Friction Washer	1
3J	60145001	Shank Nut	1
4	G67871	Base Ass'y.	1
5	59517007	Long Cold Cartridge	1
6	59517008	Long Hot Cartridge	1
7	60445001	Nut	2
8	G67911	Valve Body Ass'y.	1
9	59532001	1/2" NPSM Riser Nut	2

Z831A1-XL-ICT PICTURED

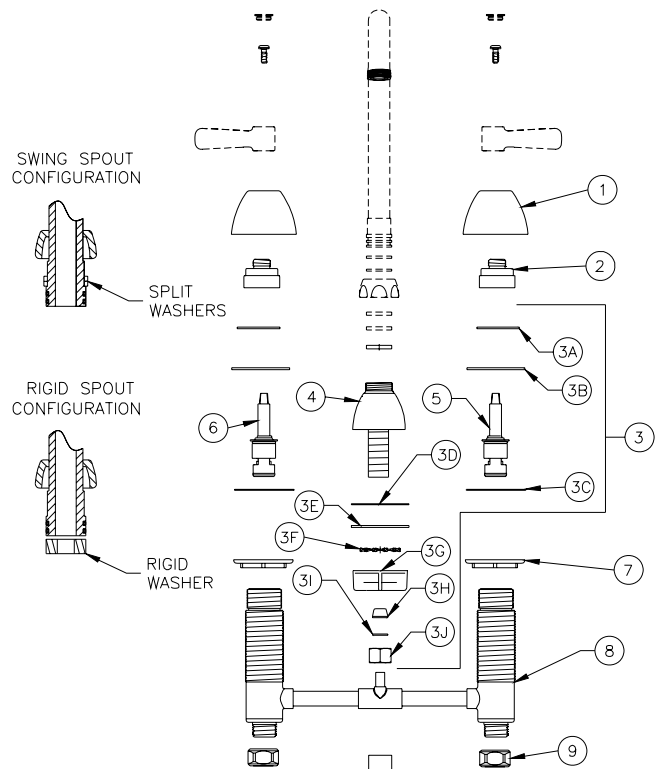

FIGURE 3

Item	Part Number	Description	Qty.
1	60077001	Cartridge Cap	2
2	60078001	Escutcheon	2
3	G61859	Mounting Hardware	1
3A	60383002	Retaining Ring	2
3B	60382001	Washer	2
3C	60444001	Washer	2
3D	60148002	Gasket	2
3E	65340001	Washer	1
3F	61613019	Toothed Lockwasher	1
3G	59530003	Flanged Mounting Nut	1
4	G67871	Base	1
5	59517005	Long Cold Cartridge	1
6	59517006	Long Hot Cartridge	1
7	G67898	Tee Assembly	1
7A	60455001	Gasket	1
7B	63982001	Retaining Ring	1
7C	60145002	Shank Nut	1
7D	61283005	Tee	1
8	93317332	S. S. Flexible Hose	2
9	93039001	Valve Body Assembly	2
9A	60445001	Nut	2
10	59532001	1/2" NPSM Riser Nut	2

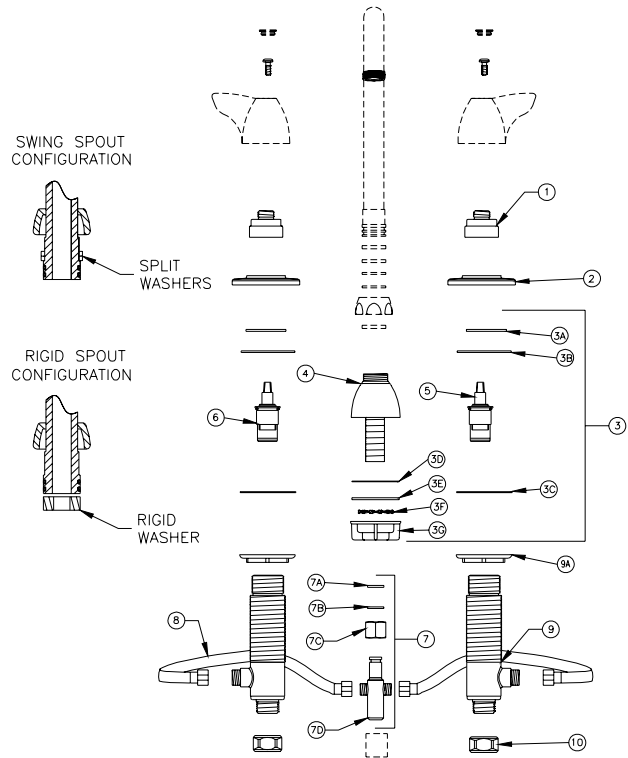

FIGURE 4

Item	Part Number	Description	Qty.
1	60078001	Escutcheon	2
2	60077001	Cartridge Cap	2
3	G61859	Mounting Hardware	1
3A	60383002	Retaining Ring	2
3B	60382002	Stainless Steel Washer	2
3C	60444001	Brass Washer	2
4	59517007	Long Cold Cartridge	1
5	59517008	Long Hot Cartridge	1
6	60082001	Threaded Escutcheon	1
7	93217001	Diverter	1
8	60457002	Diverter Extension Rod	1
9	61268004	Diverter Tee	1
10	G61073	Mounting Hardware	1
10A	60549002	Friction Gasket	1
10B	60444002	Washer	1
10C	60445002	Mounting Nut	1
11	93317332	Flexible Hose	2
12	93039001	Single Body Assembly	2
12A	60445001	Nut	2
13	59532001	1/2" NPSM Riser Nut	2
14	G67905	Hose Spray Assembly	1

Z831A1-XL-HS PICTURED

